

1. Raise vehicle on a hoist, remove road wheels, disconnect the drag-link from the passenger-side hub assembly and disconnect the steering tie rod ends from both the driver and passenger side hub assemblies.
  2. Drain the front differential fluid.
  3. Unbolt the front brake caliper assemblies from the hub assemblies and securely position away from the hub assembly working area.
  4. Remove the free-running hubs or drive flange.
- For **manual-select free-running hubs**, follow the next three steps.
    1. Set the position of the hub to 'FREE' and remove the six hex-drive bolts.

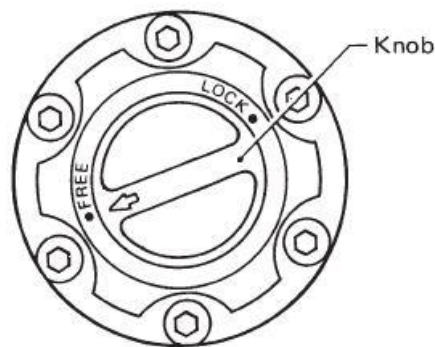

Fig 1

2. After removing the manual select free-running hub, remove the circlip and drive clutch from the axle.

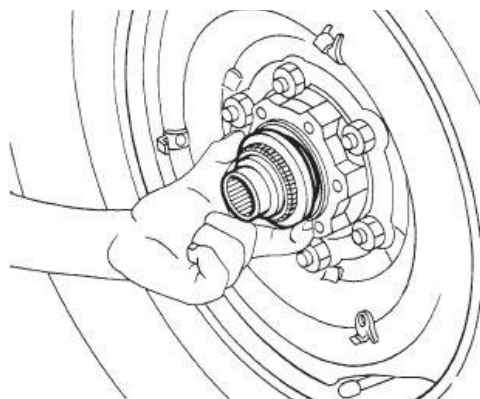

Fig 2

3. After removing the drive clutch, remove the bushing and spacer from the wheel hub.

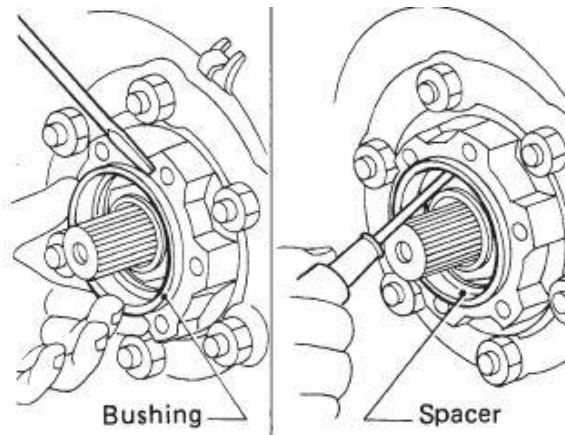

Fig 3

- For **automatic hubs**, follow the next three steps.
  1. Remove the six hex-drive bolts and then the automatic hub assembly.
  2. After removing the hub assembly, remove the circlip, brake 'B' and washer band 'A' from the axle.

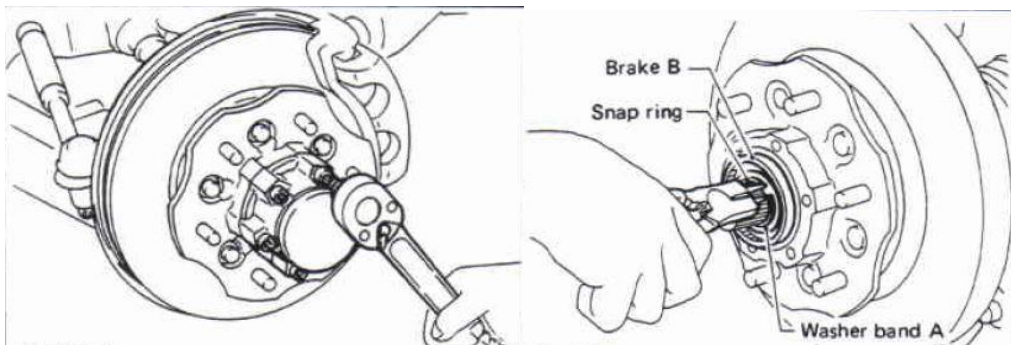

Fig 4

3. Using a #2 Phillips head screwdriver, remove the wheel bearing adjuster nut locking ring screws and then the lock ring.



Fig 5

5. Using a suitable tool, remove the wheel bearing lock nut and then the wheel hub from the vehicle.
6. Remove backing plate, grease/dust seal plate and knuckle spindle by removing the six retaining bolts.

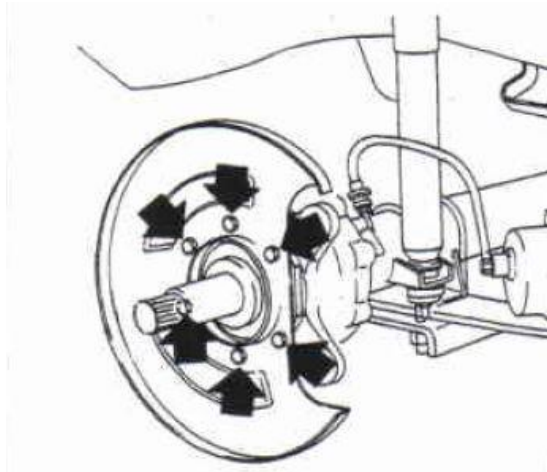

Fig 6

7. Remove the driveshaft thrust washer and then remove the driveshaft from the axle housing.

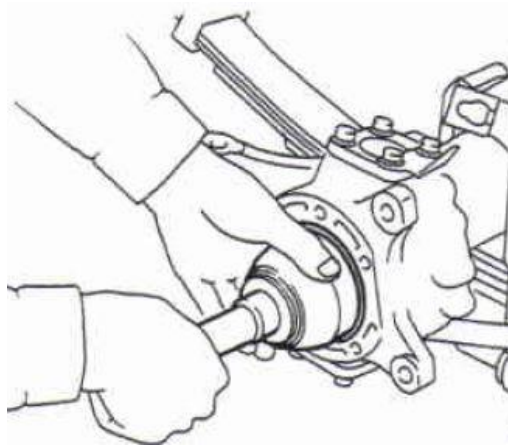

Fig 7

8. Remove the ball seal retainer bolts, remove the two-piece retainer and then dislodge the scraper, ball seal and ball seal supporting ring from the hub housing.

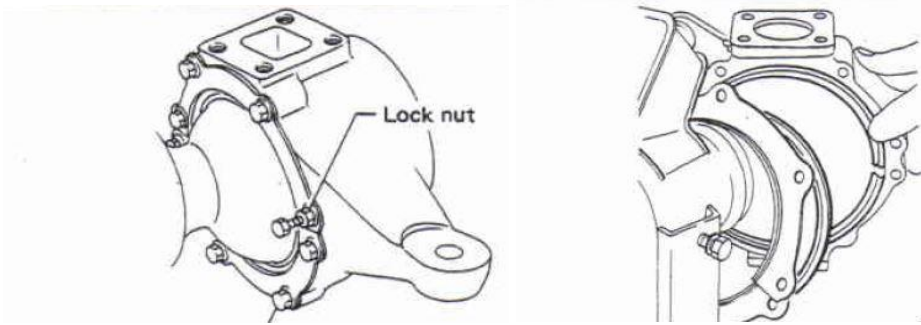

Fig 8

9. Remove the upper and lower king-pin bearing caps; ensuring the bearing preload shims (if installed) are removed also. After removing the caps and bearings, the hub housing and dislodged ball seals/retainers can be removed from the axle.

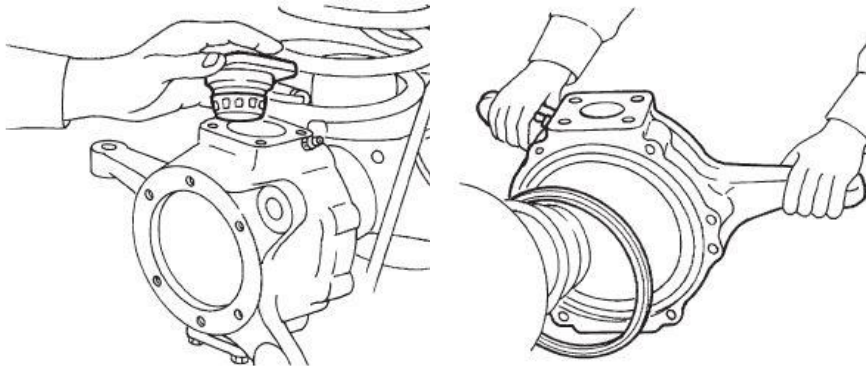
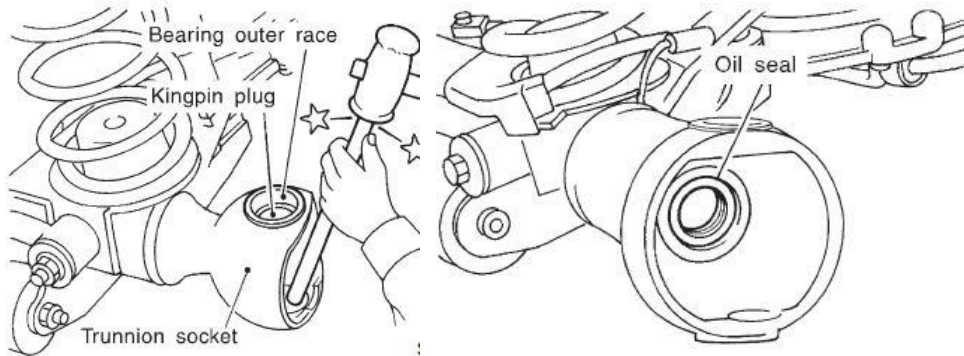

Fig 9

10. Remove the king-pin bearing caps and plugs using a suitable drift. If the plugs are damaged during this process and need replacing or are missing, the genuine Nissan part number is **40040-01J00**. After removing the king-pin bearing caps and plugs, remove the oil seal from the axle shaft.



-----Fig 10

**\*\*NOTE\*\*** At this point, it is advisable that all components be cleaned and thoroughly inspected for serviceability. Items like the axle balls, drive shafts and hub knuckle assemblies should be checked for corrosion, cracks, distortion and/or other signs of excessive wear.

11. Install the supplied new axle seals with a suitable driver; ensuring that the spring-loaded lip of the axle seal is pointing inboard (toward the differential of the axle). After installing the axle seal, apply a small amount of grease to the lip of the seal.

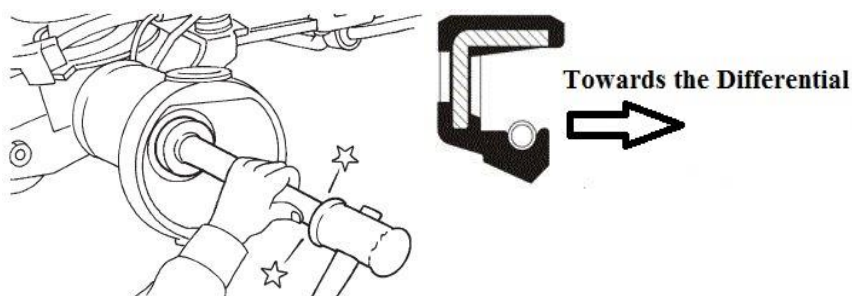

Fig 11

12. Install the supplied new king-pin bearing caps and bearing plugs with a suitable driver.

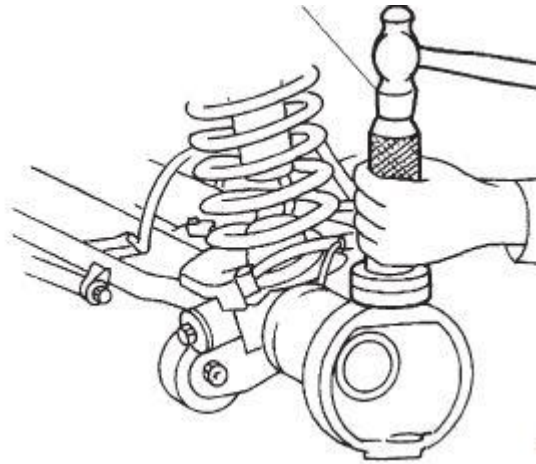

Fig 12

13. Install the rubber ball seal, the metal ball seal support ring and the plastic seal scraper over the axle ball and allow them to temporarily rest on the axle tube. When eventually installed to the hub knuckle, the orientation of the ball seal, retainer and scraper is as per the images below. Use these orientation diagrams (Figs 14 & 15) as guides when installing these seals.

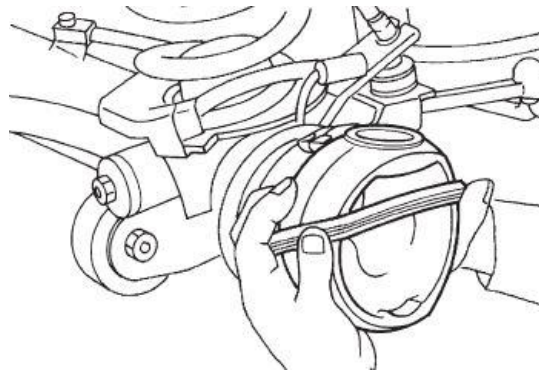

Fig 13



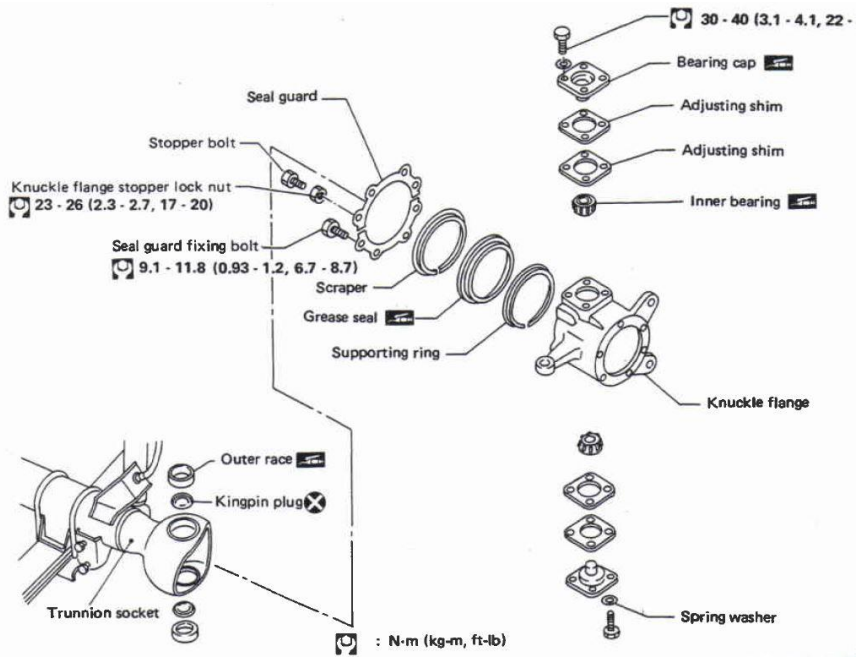

Fig 14

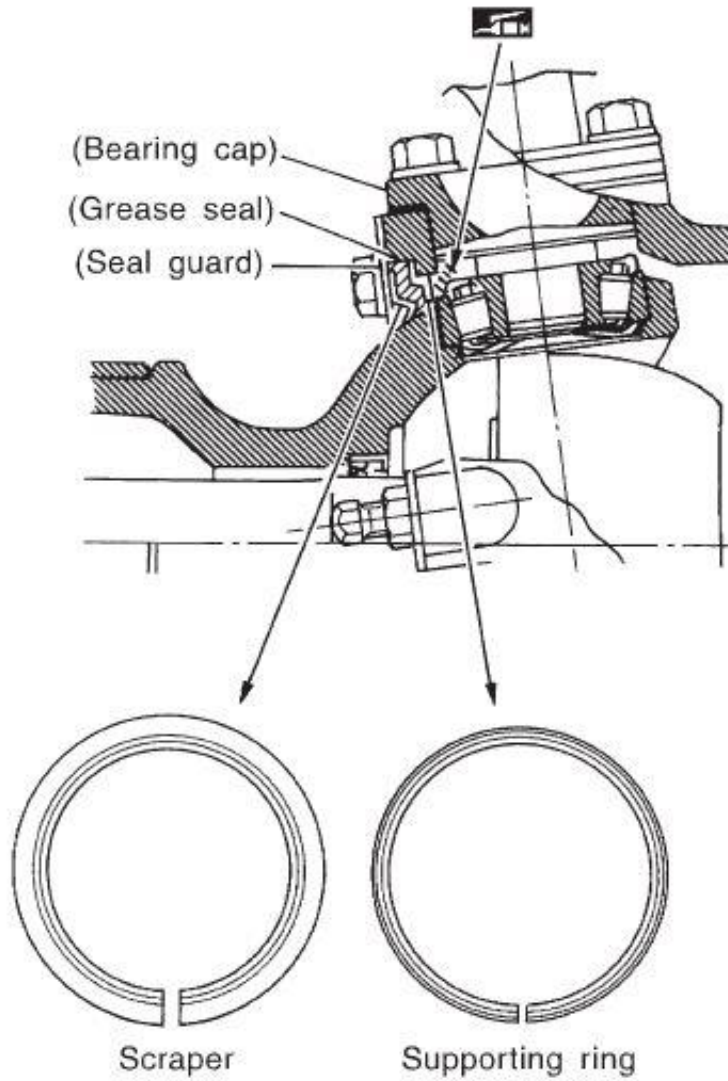

Fig 15

14. Apply a thin layer of grease to the seal surface of the axle ball and pack the new king-pin bearings with a quality bearing grease in preparation for installation. Install the hub knuckle loosely over the axle ball.

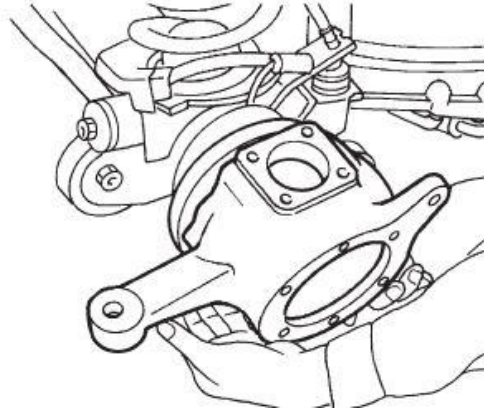

Fig 16

15. Install the new grease-packed bearings to the king-pin caps; ensuring that the preload shims (if originally installed) are in position. Install the bearing caps to the hub knuckle and tension the bearing cap bolts to 30-40 Nm. Adjust rotating force of knuckle flange (at hinge pin) to 5.8 to 17.1 N (0.6 to 1.75 kg) range by adding or removing upper and lower shims of same thickness. The shim pack thicknesses of the upper and lower bearings **must** be exactly the same so that the drive shaft (when installed) is centralised within the axle. If required, additional shims can be purchased via Nissan.

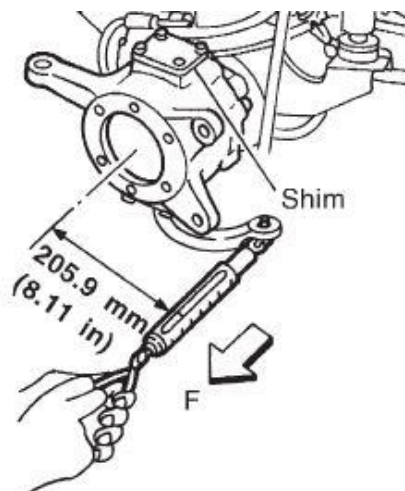

Fig 17



16. Install the axle ball seal supporting ring, ball seal and ball scraper ring as per figures 14 & 15. Reinstall the grease seal guard/retainer as per fig 18.

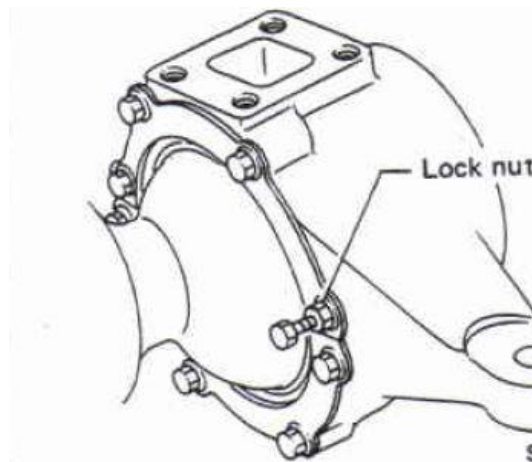

Fig 18

17. Repack the cleaned CV joint of the driveshaft with a CV joint-specific grease and reinstall the driveshaft into the axle. Fill the hub cavity around the CV joint to approx.  $\frac{3}{4}$  capacity with a CV joint-specific grease. Also install the driveshaft thrust washer.

18. Remove the spindle flange seal and axle needle roller bearing from the knuckle spindle and replace both with the new supplied items. Apply a small amount of grease to both items.

19. Apply a thin layer of oil resistant sealant to the spindle-to-knuckle sealing face and mount the spindle, brake dust shield and dust seal plate to the knuckle (Refer fig 6). Tension the spindle flange bolts to 30-40 Nm.

20. Pack the cleaned original or new wheel bearings (Pedders part #512202) with a premium wheel bearing grease. Also pack the bearing cavity of the wheel hub with a suitable amount of the same grease. Install the inboard wheel bearing into the wheel hub and install the new supplied wheel hub seal.

**\*\*NOTE\*\*** the twin lips of the wheel hub seal face inboard when the hub is installed to the axle. Apply a small amount of grease to the lips of the wheel hub seal.

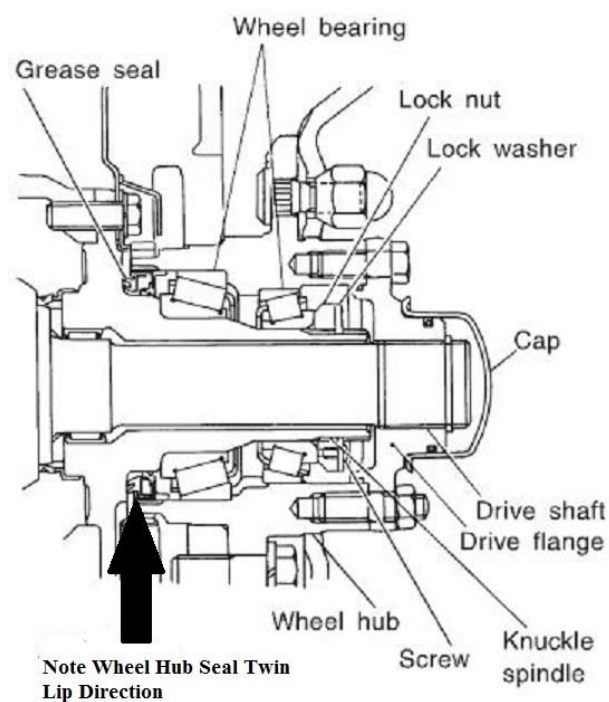

Fig 19

21. Install the outer wheel bearing to the hub and then install the hub to the knuckle spindle. Secure the hub with the lock nut and adjust the wheel bearing preload.

- For **manual-select free-running hubs**: Once the wheel bearing preload is set, install the supplied new lock washer and lock nut. Tighten the lock nut and bend the lock washer against the lock nut to secure it from moving.

- For **automatic hubs**: Once the wheel bearing preload is set, secure the wheel bearing adjusting nut with the lock washer and screw(s). Refer to fig 20.

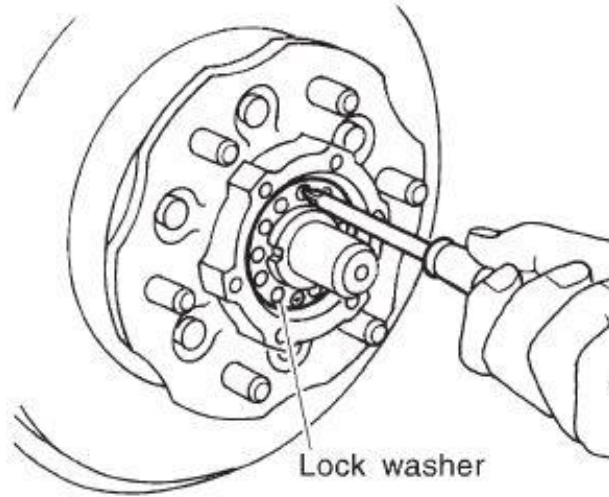

Fig 20

22. Install the free-running hub's mating parts (such as thrust washer and spindle washer for the Auto-hub or the drive clutch for manual hubs) on the drive shaft and select a suitable snap ring so that end play between drive shaft and its mating parts is within specifications.

**Axial end play: 0.4 mm or less**

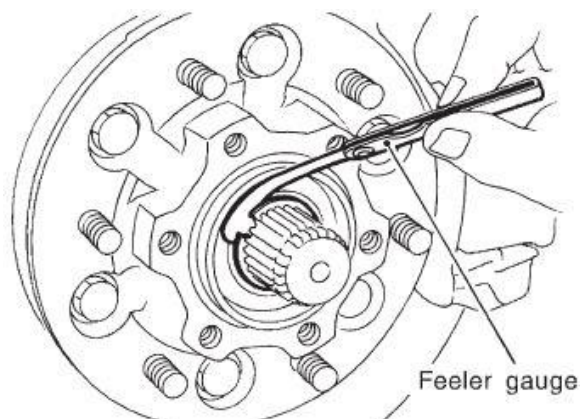

Fig 21

23. Install the free-running hub assembly to wheel hub. Ensure that a small amount of oil resistant sealant is applied to the mating surfaces.

**For Manual free-running hubs:**

Ensure that the hubs are set to the 'Free' position before installing

24. Reinstall the brake calipers and bleed the brake hydraulic system if necessary. Reconnect the drag-link to the passenger-side hub assembly and reconnect the steering tie rod ends to both the driver and passenger side hub assemblies. Refill the front differential with the correct fluid. Reinstall the road wheels and check the correct adjustment of the steering lock-stops.

**\*\*Note\*\*** It is advisable to have a wheel alignment completed after the installation of the Pedders 512113 swivel hub rebuild kit.